

DRIVEN

SIDE-BY-SIDE REFRIGERATOR / FREEZER
DELUXE DESIGN / HIGH EFFICIENCY
REFRIGERATION SERIES



Instruction Manual

MODEL: R-700S-D (Stainless/Black)

Before using your refrigerator, please read this manual carefully and keep it for future reference.



Welcome & Congratulations

Thank you for purchasing this quality CONTOURE™ appliance.

Congratulations on your new Deluxe Side-by-Side Refrigerator/Freezer.

For your safety and full enjoyment of this product, always read the instruction book carefully before using.

Don't forget to register your product at www.contoureusa.com for updates and other relevant information.

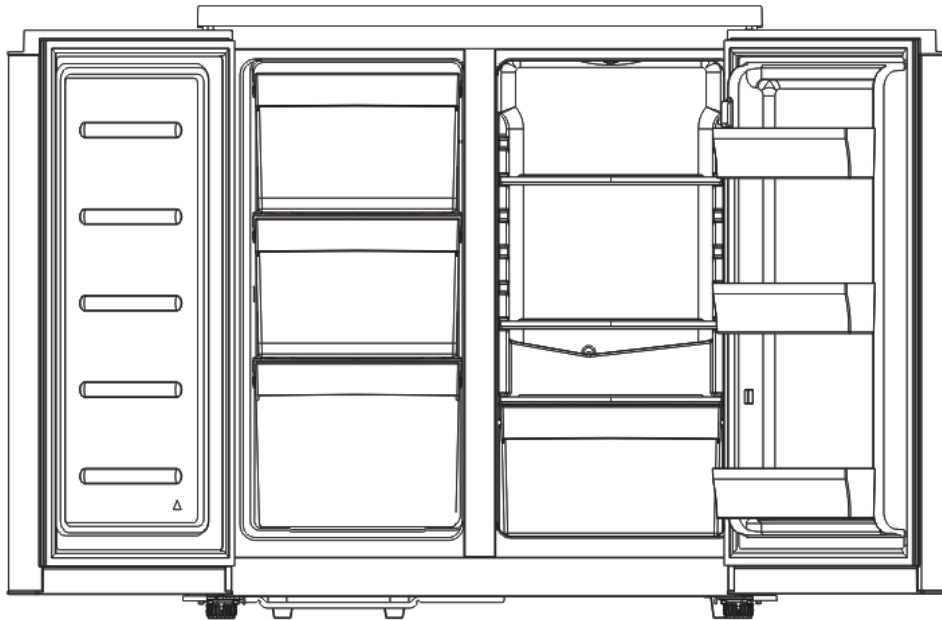

Photograph above shows full refrigerator / freezer diagram.

This manual contains important information on the installation, use, and care of your appliance. Please read this manual carefully before installation and operation of this machine to prevent injury and property damage and to take full advantage of your appliances benefits and features.

SAVE THESE INSTRUCTIONS



Contents

Safety And Precautions	2
Safety and precautions	2
Important safety instructions	4
Important safe guides	5
Critical installation warnings	6
Installation Requirements	7
Parts and accessories	7
Before using your appliance	8
Installation	9
Electrical requirements	10
Electrical connection	11
Getting Started	12
Operating your appliance	12
Defrosting your appliance	13
Freezing fresh foods	14
Care And Maintenance	15
Relocating your appliance	16
Troubleshooting Tips	17
Servicing your Appliance	18
Warranty	19
Obtaining Service	20



Safety and Precautions

SAFETY AND PRECAUTIONS

Thank you for purchasing this quality CONTOURE™ appliance.

This manual contains important information on the installation, use, and care of your appliance. Please read this manual carefully before installation and operation of this machine to prevent injury and property damage.

WHAT YOU NEED TO KNOW ABOUT SAFETY INSTRUCTIONS

Warnings and Important Safety Instructions in this manual DO NOT cover all possible conditions and situations that may occur. It is your responsibility to use common sense, caution and care when installing, maintaining and operating this appliance.

IMPORTANT SAFETY SYMBOLS AND PRECAUTIONS WARNING



This symbol indicates that hazards or unsafe practices may cause **serious personal injury or death**.

To reduce the risk of fire, explosion, electric shock, or personal injury when using your appliance, these basic safety precautions **MUST** be followed.

These warnings are to prevent injury to you and to others. Please follow the explicitly.

After reading this section, keep it in a safe place for future reference.

STATE OF CALIFORNIA PROPOSITION 65 WARNINGS



WARNING

The California Safe Drinking Water and Toxic Enforcement Act requires the Governor of California to publish a list of substances known to the State of California to cause cancer, birth defects, or other reproductive harm, and requires business to warn of potential exposure to such substances.

This product contains a chemical known to the State of California to cause cancer, birth defects, or other reproductive harm. This appliance can cause low-level exposure to some of the substances listed, including benzene, formaldehyde, and carbon monoxide.

SAVE THESE INSTRUCTIONS



Safety and Precautions

REFRIGERATOR SAFETY

Your safety and the safety of those around you is very important.

This manual contains important information on the installation, use, and care of your appliance. Please read this manual carefully before installation and operation of this machine to prevent injury and property damage.

All safety messages will follow the Safety Alert Symbol and either the words “DANGER,” “WARNING,” or “CAUTION.”



DANGER means that failure to heed this safety statement may result in severe personal injury or death.



WARNING means that failure to heed this safety statement may result in extensive product damage, serious personal injury, or death.



CAUTION means that failure to heed this safety statement may result in minor or moderate personal injury, property or equipment damage.

All safety messages will alert you to know what a potential hazard is, tell you how to reduce the chance of injury and let you know what can happen if the instructions are not properly followed.

STATE OF CALIFORNIA PROPOSITION 65 WARNINGS



The California Safe Drinking Water and Toxic Enforcement Act requires the Governor of California to publish a list of substances known to the State of California to cause cancer, birth defects, or other reproductive harm, and requires business to warn of potential exposure to such substances.

This product contains a chemical known to the State of California to cause cancer, birth defects, or other reproductive harm. This appliance can cause low-level exposure to some of the substances listed, including benzene, formaldehyde, and carbon monoxide.

For more information go to www.p65warnings.ca.gov.

SAVE THESE INSTRUCTIONS



Safety and Precautions

IMPORTANT SAFEGUIDES

BEFORE the refrigerator is used, it must be properly positioned and installed as described in this manual. Please read the manual carefully. To reduce the risk of fire, electrical shock, or injury when using the refrigerator, follow basic precautions, including the following:



- Plug into a grounded 3-prong outlet, do not remove grounding prong, do not use an adapter, and do not use an extension cord.
- It is recommended that a separate circuit, serving only your refrigerator be provided. Use receptacles that cannot be turned off by a switch or pull chain.
- Never clean refrigerator parts with flammable fluids. These fumes can create a fire hazard or explosion. And do not store or use gasoline or other flammable vapors and liquids in the vicinity of this or any other appliance. The fumes can create a fire hazard or explosion.
- Before proceeding with cleaning and maintenance operations, make sure the power line of the unit is disconnected.
- DO NOT connect or disconnect the electric plug when your hands are wet.
- Unplug the refrigerator or disconnect power before cleaning or servicing. Failure to do so can result in electrical shock or death.
- DO NOT attempt to repair or replace any part of your refrigerator unless it is specifically recommended in this manual. All other servicing should be referred to a qualified technician.

SAVE THESE INSTRUCTIONS



Safety and Precautions

IMPORTANT SAFEGUIDES

Please follow WARNING call-outs below only when applicable to your model:



- Use two or more people to move and install refrigerator. Failure to do so can result in back or other injury.
- **The tubing shall be protected to the extent that it will not be grasped or handled during moving of the product. During the movement of the product, should not damage the refrigerant circuit.**
- To ensure proper ventilation for your refrigerator, the front of the unit must be completely unobstructed. Choose a well-ventilated area with temperatures above 60°F (16°C) and below 90°F (32°C). This unit must be installed in an area protected from the element, such as wind, rain, water spray or drips.
- The refrigerator should not be located next to ovens, grills or other sources of high heat.
- The refrigerator must be installed with all electrical, water and drain connections in accordance with state and local codes. **A standard electrical supply (115 V AC only, 60 Hz), properly grounded in accordance with the National Electrical Code and local codes and ordinances is required.**
- DO NOT kink or pinch the power supply cord of refrigerator.
- The fuse (or circuit breaker) size should be 15 amperes.
- It is important for the refrigerator to be leveled in order to work properly. You may need to make several adjustments to level it.
- All installation must be in accordance with local plumbing code requirements.
- Make certain that the pipes are not pinched or kinked or damaged during installation.
- Check for leaks after connection.
- Never allow children to operate, play with or crawl inside the refrigerator.
- Although the unit has been tested at the factory, due to long-term transit and storage, the first batch of ice cubes must be discarded.
- DO NOT use solvent-based cleaning agents or abrasives on the interior. These cleaners may damage or discolor the interior.
- DO NOT use this apparatus for anything other than its intended purpose.

SAVE THESE INSTRUCTIONS



Safety and Precautions

CRITICAL INSTALLATION WARNINGS



The installation of this appliance **MUST** be performed by a qualified technician or service company.

Failing to have a qualified technician or service company install the oven may result in electric shock, fire, an explosion, problems with the product or injury.

Keep all packaging materials out of the reach of children. **DO NOT** allow children to use them for play.

THINGS TO REMEMBER

READ this guide carefully it is intended to help you operate and maintain your new Refrigerator/Freezer.

Keep your ORIGINAL proof of purchase receipt with this guide to help during the warranty period.

If you need to locate your model number or unit serial number you can find them on the plate located on the rear wall of your appliance. Use these numbers in any correspondence or repair request.

If you received a damaged Refrigerator/Freezer, **IMMEDIATELY** contact the dealer that sold you the unit.

Save time and money, before calling for service please check the TROUBLESHOOTING GUIDE located in the back of the manual. It lists causes of minor operating problems that you can correct yourself.

CAUTION

THIS REFRIGERATOR / FREEZER IS NOT DESIGNED FOR THE STORAGE OF MEDICINE OR OTHER MEDICAL PRODUCTS.

SAVE THESE INSTRUCTIONS



Parts & Accessories

SETTING UP YOUR REFRIGERATOR/FREEZER

Thank you for purchasing this quality CONTOURE™ appliance. We are excited for you to get started using your new outdoor refrigerator/freezer.

Remove all packaging materials and accessories from the carton and oven cavity.

Examine your new unit for any damage, like dents, or a broken door. **DO NOT** continue with installation if the unit is damaged.

Your new refrigerator / freezer comes with the following accessories:

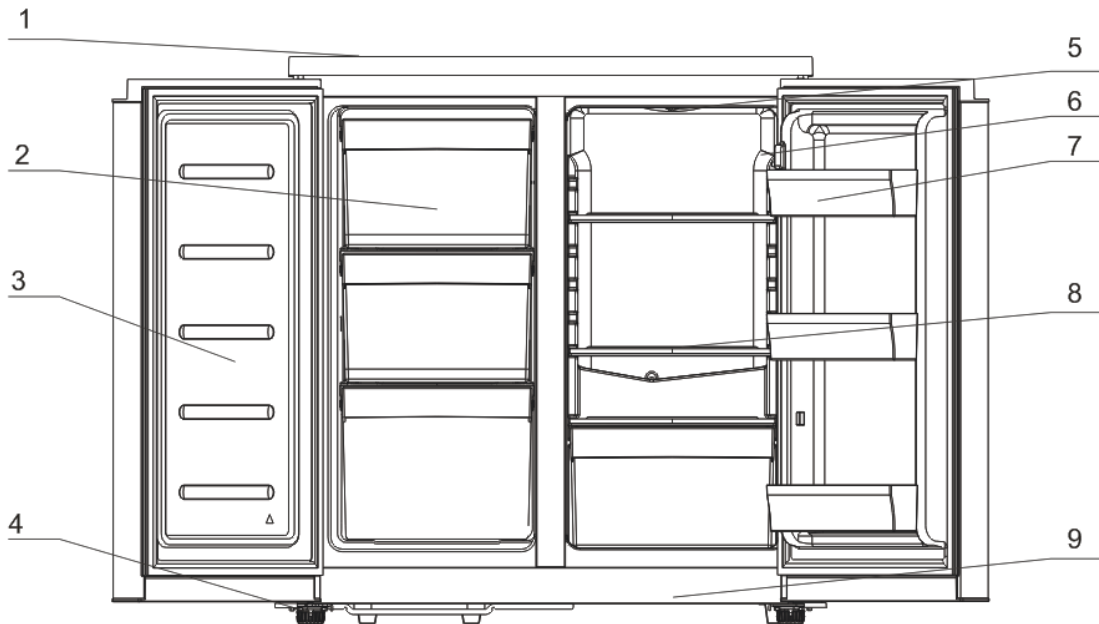

1. Decorative Countertop
2. Freezer top drawer
3. Freezer door
4. Leveling Legs
5. Interior Light
6. Light switch
7. Door bins (3-in total)
8. Refrigerator Shelves (3-in total)
9. Cabinet



Installation Requirements

IMPORTANT SAFETY INSTRUCTIONS



To reduce the risk of fire, electrical shock or injury when using your new model refrigerator/freezer, follow these basic precautions:

Read all instructions before using the refrigerator-freezer.

DANGER or WARNING: Risk of child entrapment. Child entrapment and suffocation are not problems of the past. Junked or abandoned refrigerator-freezers are still dangerous. . . even if they will “just sit in the garage a few days.”

Before you throw away your old refrigerator-freezer: Take off the doors. Leave the shelves in place so that children may not easily climb inside.

Never allow children to operate, play with, or crawl inside the refrigerator-freezer.

Never clean refrigerator-freezer parts with flammable fluids. The fumes can create a fire hazard or explosion.

Do not store or use gasoline or any other flammable vapors and liquids in the vicinity of this or any other refrigerator-freezer. The fumes can create a fire hazard or explosion.

BEFORE USING YOUR APPLIANCE

REMOVE all of the exterior and interior packaging.

Check to be sure you have ALL of the following parts:

- 3 Glass Refrigerator Shelves
- 3 Door Bins
- 1 Instruction Manual

Before connecting the unit to the power source, let it set upright for approximately 2 hours. This will reduce the possibility of a malfunction in the cooling system from handling during transportation.

Clean the interior surface with lukewarm water using a soft cloth.

SAVE THESE INSTRUCTIONS



Safety & Installation

INSTALLATION OF YOUR APPLIANCE

Place your refrigerator-freezer on a floor that is strong enough to support the refrigerator-freezer when it is fully loaded. To level your Refrigerator/Freezer, adjust the leveling legs at the bottom of unit.

Allow 15cm of space between the back and sides of the unit, which allows the proper air circulation to cool the compressor and condenser.

Place the unit away from direct sunlight and sources of heat (stove, heater, radiator, etc.). Direct sunlight may affect the acrylic coating and heat sources may increase electrical consumption. Extreme cold ambient temperatures may also cause the Refrigerator/Freezer not to perform properly.

Avoid placing the unit in moist areas.

Plug the unit into an exclusive **properly installed-grounded wall outlet**.

DO NOT under any circumstances cut or remove the third (ground) prong from the power cord. Any questions concerning power and/or grounding should be directed toward a certified electrician.

SAVE THESE INSTRUCTIONS



Safety & Installation

ELECTRICAL CONNECTION

⚡ Warning ⚡
**Improper use of the grounded plug can result in the risk of electrical shock.
If the power cord is damaged, have it replaced by an authorized service**

This appliance should be properly grounded for your safety. The power cord of this appliance is equipped with a three-prong plug which mates with standard three prong wall outlets to minimize the possibility of electrical shock.

DO NOT under any circumstances cut or remove the third ground prong from the power cord supplied. For personal safety, this appliance must be properly grounded.

The cord should be secured behind the appliance and not left exposed or dangling to prevent accidental injury.

The appliance should always be plugged into its own individual electrical outlet which has a voltage rating that matches the rating label on the appliance. This provides the best performance and also prevent overloading house wiring circuits that could cause a fire hazard from overheated. Never unplug the appliance by pulling the power cord. Always grip the plug firmly and pull straight out from the receptacle. Repair or replace immediately all power cords that have become frayed or otherwise damaged. Do not use a cord that shows cracks or abrasion damage along its length or at either end. When moving the appliance, be careful not to damage the power cord.

EXTENSION CORD

It is **STRONGLY** recommended that you do not use an extension cord with this appliance to avoid potential safety hazards under certain conditions.

If you do decide to use an extension cord it is **absolutely necessary** that it be a UL/CUL-Listed, 3-wire grounding type appliance extension cord having a grounding type plug and outlet and that the electrical rating of the cord be 220 volts.

SAVE THESE INSTRUCTIONS



Safety, Precautions & Installation

ELECTRICAL CONNECTION (continued)

⚡ Warning ⚡
Improper use of the grounded plug can result in the risk of electrical shock.
If the power cord is damaged, have it replaced by an authorized service

SURGE PROTECTOR

Most electrical appliances use a series of electric control boards to operate. These boards are very susceptible to power surges and could be damaged or destroyed.

If the appliance is going to be used in an area or if your city / country is prone to power surges / outages; it is suggested that you use a power surge protector for all electrical devices / appliances you use. The surge protector that you select must have a surge block high enough to protect the appliance it is connected to. If you have any questions regarding the type and size of surge protector needed contact a licensed electrician in your area.

Damages due to power surges are not considered a manufacturer covered defect and will void your product warranty.

SAVE THESE INSTRUCTIONS



Getting Started

OPERATING YOUR APPLIANCE (SETTING THE TEMPERATURE CONTROL)



The temperature control is located in the refrigerator section.

This control will adjust the temperature for both the refrigerator and freezer sections.

The first time you turn the unit on, set the temperature control to “7” the coldest.

The range of the temperature controls are from position “0” or NO COOLING to “7” the coldest.

After 24 to 48 hours, adjust the temperature control to the setting that best suits your needs.

We recommend the setting number “5” setting for standard refrigerator use.

INTERIOR LIGHT

When you open the door the light automatically TURN ON.

When you close the door the light will automatically turn OFF automatically.

DEFROSTING YOUR APPLIANCE

For the most efficient operation of your Refrigerator/Freezer and to minimize energy consumption we recommend defrosting the freezer compartment when the frost on the appliance walls exceeds ~1cm in thickness.

There is no need to defrost the refrigerator compartment. Any ice that is deposited on the inner back wall will defrost automatically.

Ice may build up on the inner back wall during operation. The unit is designed so when the compressor is not operating ice will automatically begin to defrost. Water droplets collected during this process will drain through to an outlet in the inner back wall of the unit onto a drain pan located above the compressor. From there the water will evaporate.



Getting Started

DEFROSTING YOUR APPLIANCE (continued)

DO NOT use boiling water to attempt to defrost your appliance. This may damage some of your Refrigerator/Freezer's components.

NEVER use a sharp or metallic instrument to remove frost from your appliance. It may damage the cooling coils and will void the warranty. Should you desire to remove frost from your appliance, we recommend using a plastic scraper.

HOW TO DEFROST YOUR APPLIANCE

Reset the thermostat to the "0" position and disconnect the power supply.

Remove the frozen food from the appliance and place it in a cooler to keep cool.

Leave the door open for a while so that you can easily scrape frost off of the surface. Please remember DO NOT use sharp or metallic instruments to remove frost from your appliance.

When using a PLASTIC scrapper be careful NOT to damage the inner surface of the freezer.

Wipe up the scrapped up frost and ice to remove it before it is completely defrosted.



Getting Started

Proper use of this appliance, adequately packed food, correct temperature settings and taking into account hygienic precautions will substantially influence the quality of freezing your food and/or storing frozen foods.

The freezer compartment is designed for the "long-term" storage of frozen food.

The "life" of the foods stored varies and we recommend that you do not exceed the storage times given by the food manufacturer.

Pre-packaged or commercially frozen foods should be stored in accordance with the frozen food's manufacturer instructions.

Carefully select the food you intended to freeze to make sure it is of adequate quality and suitable for freezing.

Use correct packaging and wrap foods tightly when freezing. Packaging should be airtight and shouldn't leak.

Take all necessary sanitary precautions when preparing foods to be frozen. Foils and bags should be soft enough to tightly wrap around the foods you are preparing to freeze.

We recommend marking packages with date of freezing, type and amount of food frozen.

If the load amount inside of the freezer is too large, the quality of freezing will be reduced whereby affecting the quality of frozen food. Please be careful not to overload your freezer's capacity.



Care and Maintenance

CLEANING YOUR APPLIANCE

The interior surface of your Refrigerator/Freezer is designed to NOT absorb odors but we recommend an occasional wipe down with a water/baking soda solution to keep the inside fresh. (EXAMPLE: 2 tablespoons of baking soda for every 1 quart of warm water).

Before cleaning, turn the temperature dial to “0” and **unplug the unit**.

DO NOT clean any part of this appliance without unplugging the cord.

CAUTION failure to unplug the Refrigerator/Freezer could result in electrical shock or personal injury.

Carefully remove food and baskets and place them in a cooler to protect your food.

The outside of the unit should be cleaned with mild detergent and warm water.

DO NOT use abrasive cleaners or sharp utensils to clean your appliance.

DO NOT use commercial cleaners on any part of your appliance.

DO NOT drop the shelves inside your unit or they may break.

POWER FAILURE

Most power failures are corrected within a few hours and should not affect the temperature of your Refrigerator/Freezer if you minimize the number of times the door is opened.

If the power is going to be off for a longer period of time, you need to take the proper steps to protect your food.

VACATION TIME

If you are not going to use your unit for a short period of time, you may leave the unit operating for a period of three weeks or less.

If you are not going to use your appliance for several months, remove all food and unplug the power cord. Clean and dry the interior thoroughly. To prevent odor and mold growth, leave the door slightly open.



Care and Maintenance

RELOCATING YOUR APPLIANCE

If you wish to relocate your Refrigerator/Freezer please follow the following steps:

- Remove ALL food (place food in a cooler if necessary)
- Securely tape down ALL loose items inside the unit (including glass shelves and /or storage bins.
- Turn the levelling screws up to the base of the unit to avoid damage
- Tape both, refrigerator and freezer doors shut
- Be sure the unit REMAINS in the upright position during transportation

TIPS TO SAVE ENERGY & REDUCE CONSUMPTION

If possible, keep your unit in the coolest area of the room, away from heat producing appliances or heating ducts, and out of direct sunlight.

Allow hot foods cool to room temperature before placing them in the refrigerator. Overloading the unit forces the compressor to run longer. Foods that freeze too slowly may lose quality, or spoil.

Be sure to wrap foods properly, and wipe containers dry before placing them in the unit. This cuts down on frost build-up inside the freezer.

Organize and label food to reduce door openings and extended heat exposure by leaving the door open when searching for foods.

Remove as many items as needed at one time, and close the door as soon as possible.



Troubleshooting

FREQUENTLY ASKED QUESTIONS

You can solve many common "problems" with your Refrigerator/Freezer by referencing our "Frequently asked Question" guide below.

Please try these suggestions prior to calling a qualified service technician to service your unit.

UNIT DOES NOT OPERATE

- Check to be sure the unit is plugged in
- The circuit breaker may have tripped or there is a blown fuse
- The Refrigerator/Freezer temperature control is set to "0"

COMPRESSOR TURNS ON/OFF FREQUENTLY

- Check to see if the room temperature is hotter than normal
- A large amount of food has been added to the Refrigerator or Freezer exceeding the recommend load capacity
- The doors are opened too often or left open for too long
- The unit's temperature control is NOT set correctly
- The door gaskets do not seal properly
- The Refrigerator/Freezer does NOT have the correct clearance(s)

VIBRATION(S)

- Check to make sure the unit is level

THE UNIT SEEMS TO MAKE TOO MUCH NOISE

- Some rattling noise may come from the flow of the refrigerant which is normal
- As each cycle ends you may hear some "gurgling" sounds coming from the flow of refrigerant– this is normal
- Contraction and expansion of the inside walls may cause "popping" and/or "crackling" noises– this is normal
- Check to make sure the unit is sitting level

THE DOORS WILL NOT CLOSE PROPERLY

- Make sure the doors are properly installed and not reversed
- Check to make sure the unit is sitting level
- The door gasket may be dirty
- The crisper bin is not in it's proper position

If you have a problem that you cannot solve, please do not hesitate to call our service line.



Servicing your Appliance

WIRING & TECHNICAL DIAGRAM

The service of this appliance MUST be performed by a qualified technician or service company.

Failing to use a qualified technician or service company may result in electric shock, fire, an explosion, problems with the product or injury and void your warranty.

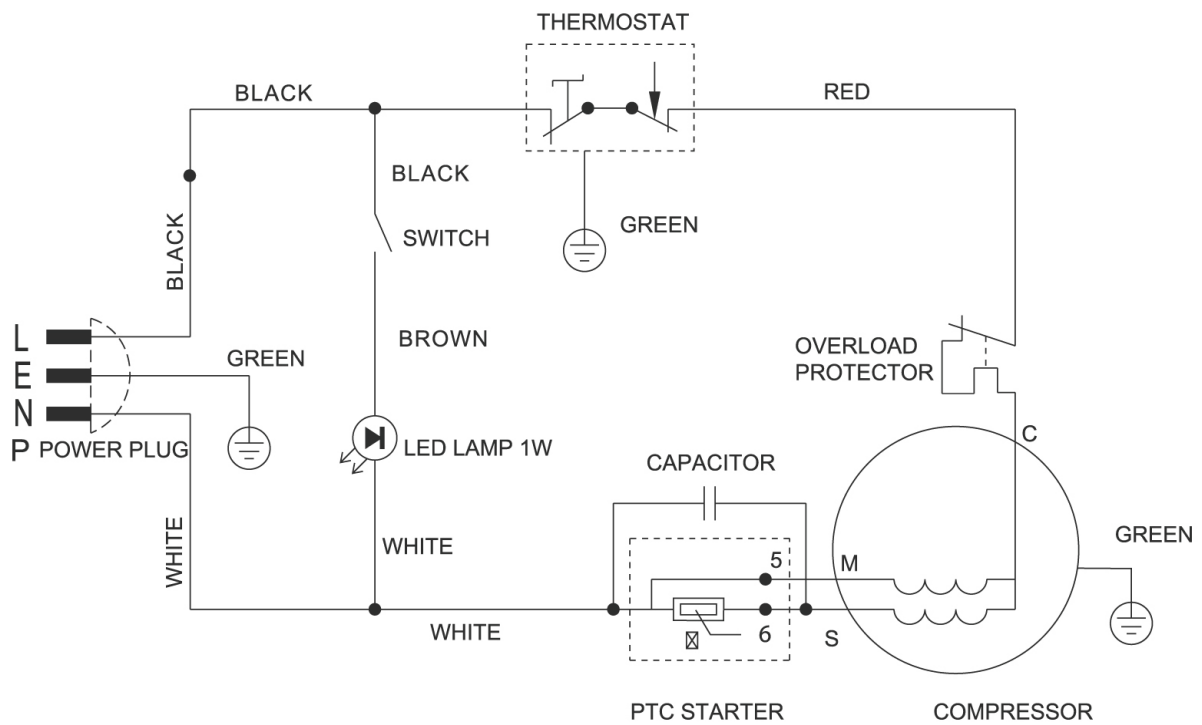



Warranty

LIMITED WARRANTY - Register your product at www.contoureausa.com

This warranty is available to consumers only. You are a consumer if you own a CONTOURE product that was purchased at a retail store for personal, family or household use. Except as otherwise required under applicable law, this warranty is not available to retailers or other commercial purchasers or owners.

Warranty registration is not mandatory, but doing so will help us to service you more quickly if you need to present a warranty claim or notify you if there is a product recall. Please go online to submit your product registration form www.contoureausa.com. Return of product registration does not eliminate the need for the consumer to maintain the original proof of purchase in order to obtain the warranty benefits. In the event that you do not have proof of purchase date, the purchase date for warranty purposes will be the date of manufacture.

NQP warrants this CONTOURE Product (“product”) will be free of all defects in material and workmanship for the applicable period specified below commencing from the date of original purchase. This warranty extends to the original buyer only.

Ninety (90) Day Full Warranty Parts & Labor: Within ninety (90) days from the date of original purchase, NQP/CONTOURE in its sole discretion, will either repair or replace, free of charge, any part proving defective in material or workmanship. All warranty repairs and service must be performed at a NQP/CONTOURE location of service by an authorized NQP/CONTOURE technician. All expenses related to replacing or repairing a defective part under this ninety (90) day warranty shall be assumed by except the cost of transporting the product to and from NQP/CONTOURE, which shall be assumed by the buyer. If the product is replaced, the replacement will be with a product that is identical or equivalent to the warranted product. If the product cannot be repaired or replaced, NQP/CONTOURE will issue a refund to the buyer for the original purchase price less that amount directly attributable to use by the buyer.

One (1) Year Limited Warranty: After the expiration of the ninety (90) day warranty, and within one (1) year from the date of original purchase, NQP/CONTOURE will replace any part proving defective in material or workmanship with a product that is identical or equivalent to the warranted part. The buyer shall assume the cost of transporting the defective product to and from NQP/CONTOURE and will assume the cost of labor associated with repair.

DISCLAIMER OF IMPLIED WARRANTIES; LIMITATION OF REMEDIES

Customer’s sole and exclusive remedy under this limited warranty shall be product repair or replacement as provided herein. Claims based on implied warranties, including warranties of merchantability or fitness for a particular purpose, are limited to one year or the shortest period allowed by law, but not less than one year. NQP/CONTOURE shall not be liable for consequential or incidental damages such as property damage and incidental expenses resulting from any breach of this written limited warranty or any implied warranty. Some states and provinces do not allow the exclusion or limitation of incidental or consequential damage or limitations on the duration of implied warranties, so these limitations or exclusions may not apply to you. This written warranty gives you specific legal rights. You may also have other rights that vary from state to state.



Warranty

How to Obtain Warranty Service: Upon discovery of any defect, malfunction, or nonconformity in the warranty-covered product, the buyer should visit www.contoureusa.com and submit a warranty claim online. For any questions regarding your warranty you may also email us at warranty@contoureusa.com

Notice to Buyer: This warranty gives the buyer specific legal rights, and the buyer may also have other rights, which vary from state to state. You have the right to bring any action at law or equity to resolve disputes concerning or to enforce the provisions of this warranty. Every implied warranty, including any statutory warranty or condition of merchantability or fitness for a particular purpose, is disclaimed except to the extent prohibited by law, in which case such warranty or condition is limited to the duration and extent of this written warranty.

For added protection and secure handling of any NQP/CONTOURE product that is being returned, we recommend that you use a traceable, insured delivery service. NQP/CONTOURE cannot be held responsible for in-transit damage or for packages that are not delivered to us. Lost and/or damaged products are NOT covered under warranty. Please be sure to include your return address, daytime phone number, description of the product defect, product model number (located on the product), original date of purchase and any additional pertinent information pertaining to the product's return.

Warranty Exclusions: This warranty does not apply to any costs, repairs or services for the following:

- Products with original serial numbers that have been removed, altered or cannot be readily determined or products purchased "as-is"
- Product that has been transferred from its original owner to another party or removed outside of the USA or Canada
- Products used in commercial setting(s)
- Service calls to correct the installation of the warranty-covered products, to explain the usage of the product to the buyer, or to reset or replace home circuit breakers or fuses
- Service calls which do not involve malfunction or defects in materials or workmanship, or for appliances not in ordinary household use or used other than in accordance with the provided instructions.
- Repairs necessitated by use other than normal home use / Products used in commercial settings
- Damage resulting from misuse, abuse, accidents, alterations, improper installation, fire, flood, acts of God or damage caused by the shipping of the product by the buyer to NQP
- Corrective work necessitated by repairs made by anyone other than a NQP authorized service technician / Rust on the interior or exterior of the unit.
- Costs incurred for disposing of the product at locations other than a NQP facility
- Food loss due to any refrigerator or freezer failure.
- Expenses for making the appliance accessible for servicing, such as removal of trim, cupboards, shelves, etc. which are not a part of the appliance when it is shipped from the factory.
- Damages to the finish of appliance or home incurred during installation, including but not limited to floors, cabinets, walls, etc.
- Damages caused by: services performed by unauthorized service companies; use of parts other than genuine NQP/CONTOURE parts or parts obtained from persons other than authorized service companies; or external causes such as abuse, misuse, inadequate power supply, accidents, fires or acts of God.
- Labor costs after ninety (90) days from your original date of purchase incurred for product repair or replacement as provided herein for carry-in appliances.



Warranty

This warranty only applies in the USA and Canada.

In the United States and Canada, your appliance is warranted by NQP/CONTOURE. NQP/CONTOURE authorizes no person to change or add any obligations under this warranty. Obligations for service and parts under this warranty must be performed by NQP/CONTOURE or an authorized service company.

California Residents only: California law provides that for In-Warranty Service, California residents have the option of returning a nonconforming product (1) to the store where it was purchased or (2) to another retail store which sells CONTOURE products of the same type. The retail store shall then, at its discretion, either repair the product, refer the consumer to an independent repair facility, replace the product, or refund the purchase price less the amount directly attributable to the consumer's prior usage of the product. If the above two options do not result in the appropriate relief to the consumer, the consumer may then take the product to an independent repair facility if service or repair can be economically accomplished.

NQP/CONTOURE and not the consumer will be responsible for the reasonable cost of such service, repair, replacement, or refund for nonconforming products under warranty.

California residents may also, according to their preference, return nonconforming products directly to NQP/CONTOURE for repair, or if necessary, replacement, by calling our Consumer Service Center toll-free at 1-888-656-9317 or sending us an email, warranty@contoureusa.com. NQP/CONTOURE will be responsible for the cost of the repair, replacement, and shipping and handling for such products under warranty.